

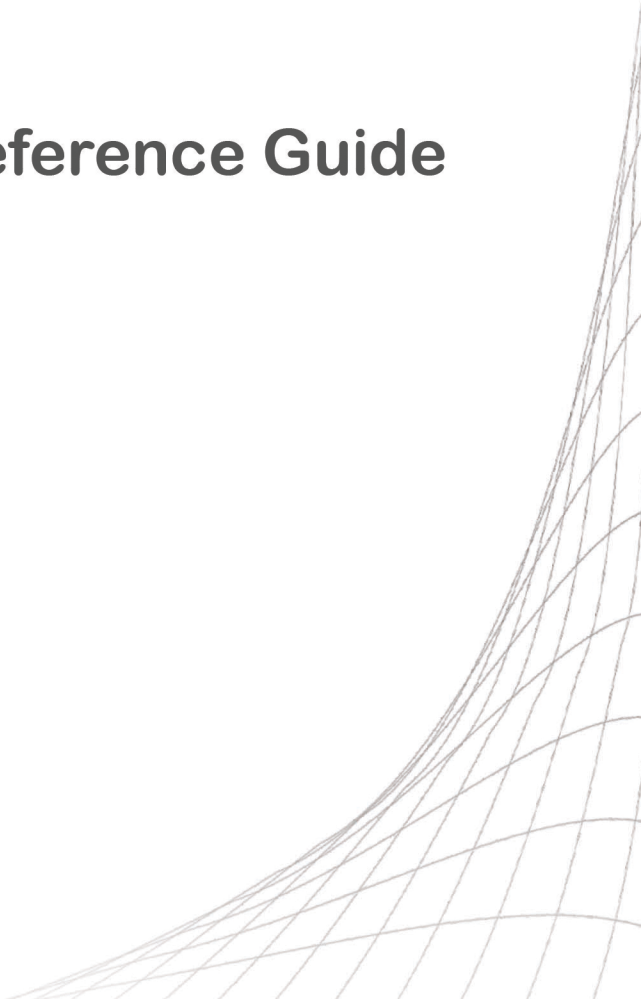

# Basic Reference Guide

**M420 Series**



# 1. Typical wiring

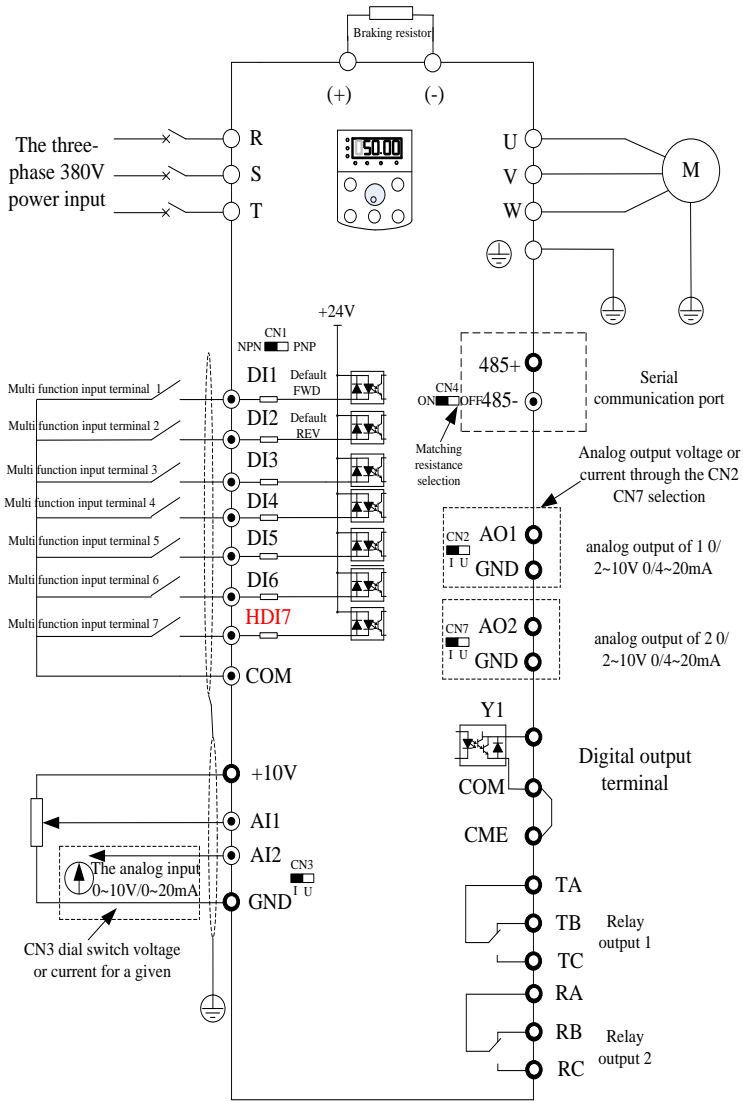

Fig.1. Inverters of 18.5KW follow

Note: this figure for ADV 1.50 M420-M ~ ADV 18.5 M420-M (1.5~18.5KW series inverter braking unit part of the matching function, if there is demand, when ordering please specify)

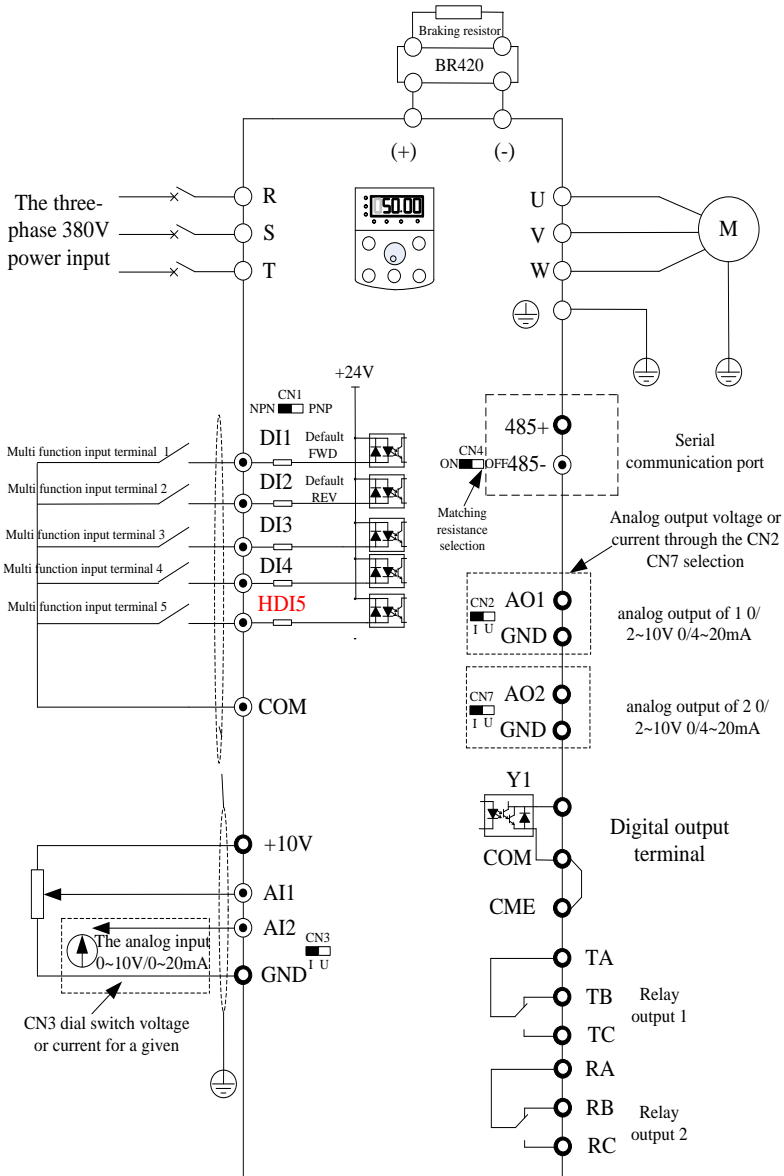

Fig.2. Inverters of 22~75Kw

Attention:

This figure is just for M420 series of inverter (22~75KW brake unit is the selective part, please declare it in order request if it's needed.)

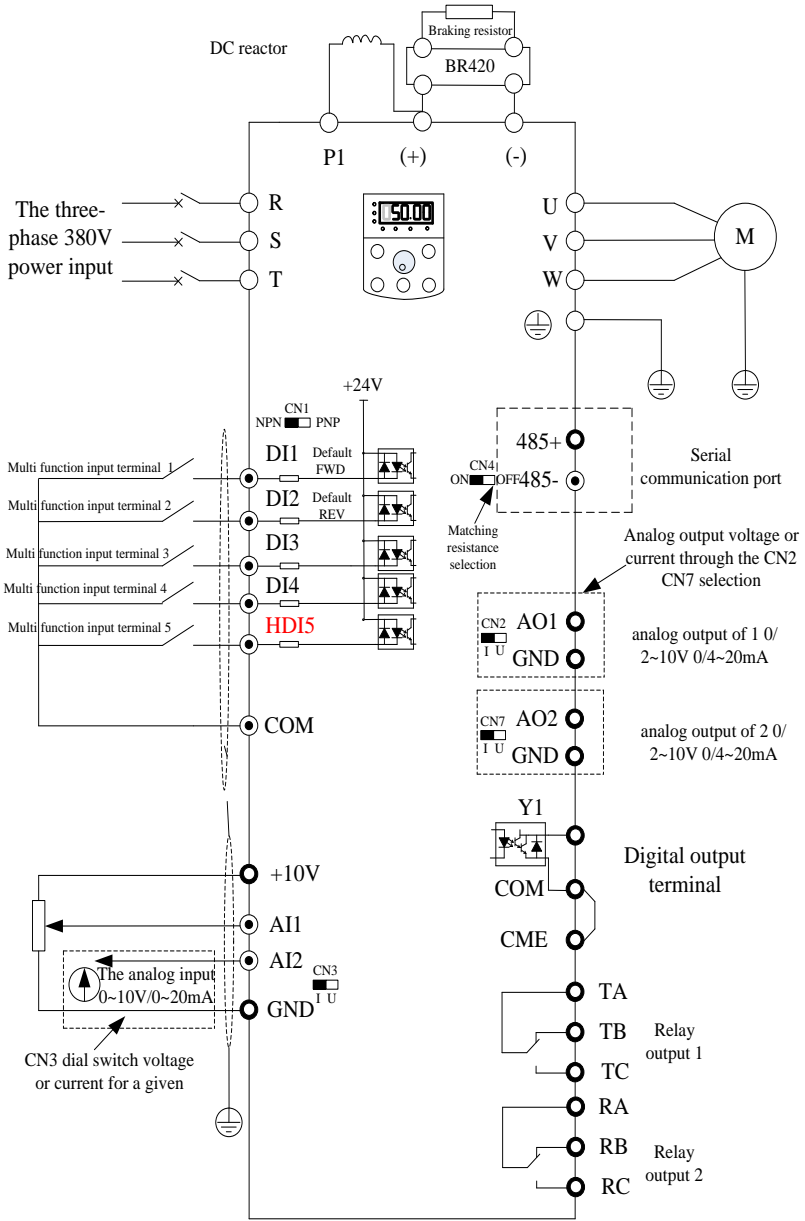



Fig.3. Three-phase inverter above 90KW

## 2. Main circuit terminals and wiring

Main circuit terminals of single-phase

Terminal	Terminal Name	Description
L1、L2	Single-phase power supply input terminals	Connect to the single-phase 220 VAC power supply
P(+), (-)	Positive and negative terminals of DC bus	Common DC bus input point.
P(+), PB	Connecting terminals of braking resistor	Connect to a braking resistor
U、V、W	Output terminals	Connect to a three-phase motor.
	Grounding terminal	Must be grounded.

Main circuit terminals of three-phase

Terminal	Terminal Name	Description
R、S、T	Three-phase power supply input terminals	Connect to the three-phase AC power supply.
P(+), (-)	Positive and negative terminals of DC bus	Common DC bus input point.
P(+), PB	Connecting terminals of braking resistor	Connect to the braking resistor for the AC drive of 7.5 kW and below (220 V) and 18.5kW and below (other voltage classes).
U、V、W	Output terminals	Connect to a three-phase motor.
	Grounding terminal	Must be grounded.

### Wiring precautions:

**Input power supply L、N or R、S、T** :

No phase sequence requirement in the input side wiring of the inverter.

**DC bus P(+), (-)** :

Pay attention that there is remaining voltage on DC bus P(+), (-) just after a power failure, only wait until the power indicate LED is off and 10 minutes after the power off, can we start the wiring operation, or there is risk of electric shock.

The wire length of the brake unit should be no more than 10m, and we should use the twisted pair and tight wire for wiring.

Don't connect the brake resistor to the DC bus directly, or it may damage the inverter and cause fire.

**Connection terminals of brake resistor** P(+), PB

How to choose the brake resistor refer to the recommended value and the wiring distance should be less than 5m, or it may damage the inverter.

**Output side of the inverter U、V、W**

The capacitor or surge absorber can't be connected to the output side of the inverter, or it may damage the inverter.

If the motor cable is too long, for the influence of the distribute capacitance, it's easily to have electrical resonance, causing the damage of the insulation or large leakage current which make the inverter over-current protection. If the length of motor cable is more than 100m, a AC output reactor should be installed near the inverter.

## 2.2. Control circuit terminals and wiring

The control circuit terminals displayed as below:

GND	GND	A01	485+	DI1	DI2	DI3	DI4	DI5	COM	COM	RA	RB	RC
10V	AI1	AI2	A02	485-	DI6	HDI7	CME	COM	Y1	24V	TA	TB	TC

Three phase 380V  $\leq$  18.5KW control terminal diagram

GND	GND	A01	485-	DI1	DI2	DI3	DI4	COM	RA	RB	RC
10V	AI1	AI2	485+	CME	COM	Y1	HDI5	24V	TA	TB	TC

Three phase 380V  $\geq$  22KW control terminal diagram

### Function instruction of the control terminals

Tab.1. Control interface function declaration of M420

Category	Terminal	Terminal Name	Function Description
Power source	+10V-GND	External +10 V power supply	Provide +10 V power supply to external unit, maximum output current: 10 mA Generally, it provides power supply to external potentiometer with resistance range of 1–5 k $\Omega$ .
	+24V-COM	External +24 V power supply	Provide +24 V power supply to external unit. Generally, it provides power supply to DI/DO terminals and external sensors. Maximum output current: 200 mA
Analog input	AI1-GND	Analog input 1	1) Input voltage range: 0–10 VDC; 2) Impedance: 100k $\Omega$
	AI2-GND	Analog input 2	1) Input range: 0–10 VDC/4–20 mA, decided by CN3 dial switches on the control board 2) Impedance: 100 k $\Omega$ (voltage input), 500 $\Omega$ (current input)
Digital input	DI1-COM	Digital input 1	1) Optical coupling isolation, compatible with dual-polarity input. Switch over through DI dial switch, factory set PNP
	DI2-COM	Digital input 2	
	DI3-COM	Digital input 3	

	DI4-COM	Digital input 4	mode. 2) Impedance: 3.3 k $\Omega$ . 3) Input voltage range: 9 ~30V 4) HDI5 can be used as high-speed input port.
	HDI5-COM	Digital input 5	
Analog output	AO1-GND	Analog output 1	Voltage or current output is decided by dial switches CN2 and CN7. Output voltage range: 0–10 V Output current range: 0–20 mA
	AO2-GND	Analog output 2	
Digital output	Y1-COME	Digital output 1	Optical coupling isolation, dual polarity open collector output Output voltage range: 0–24 V Output current range: 0–50 mA Note that CME and COM are internally isolated, but they are short circuit externally when leaving factory (In this case Y1 is driven by +24 V by default). If you want to drive Y1 by external power supply, the external short circuit of CME and COM must be switched off.
Communication interface	485+,485-	Modbus Communication terminal	Modbus communication interface, it can choose the communication matched resistance through dial switch CN4. If Profibus communication function is needed, please choose CM580 series of inverter, and use profibus DP card.
Relay output 1	T/A-T/B	NC terminal	Contact driving capacity: AC 250V, 3 A, COS $\phi$ = 0.4 DC 30V, 1A
	T/A-T/C	NO terminal	
Relay output 2	R/A-R/B	NC terminal	Contact driving capacity: 250 VAC, 3 A, COS $\phi$ = 0.4 30 VDC, 1 A
	R/A-R/C	NO terminal	
Keyboard extended line interface	CN6	External operation panel interface	External operation panel and parameter copy panel interface, take out the bidirectional crystal head, it can expand the standard network cable.

### 3. Operation and Display

#### 3.1. Operation and Display Interface Introduction

We can change the function parameter, monitor the working status and control (start up/stop) the running inverter through the operation panel. The appearance and function are like below:

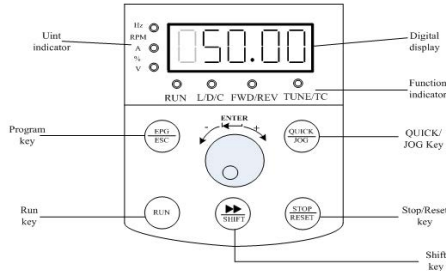

Fig.4. Schematic diagram of operation panel 1 (standard LED keyboard1)

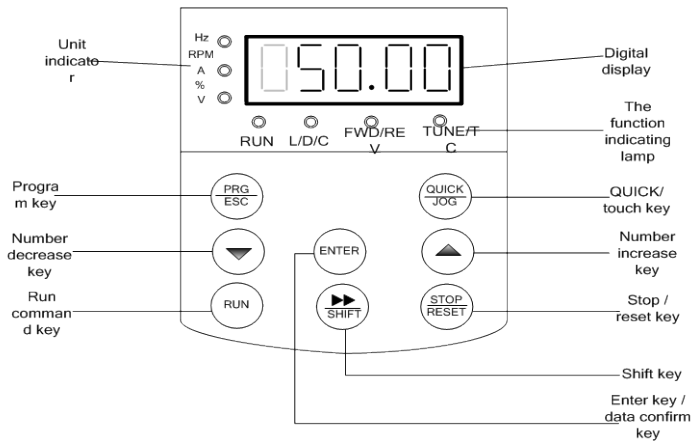

Fig.5. Schematic diagram of operation panel 2 (selective LED keyboard 2, declare in the order request if you need this panel)

Keyboard 1 and keyboard 2 switching operation mode: pressing the PRG key and the STOP key at the same time, don't release until "END" to appear, switching success.



### 3.1.1. Description of Function LED Indicator

LED Symbol		Unit	Implication	Color
Unit LED	Hz	Freq. Unit	LED on— current parameter is frequency value	Green
	A	Current Unit	LED on— current parameter is current value	Green
	V	Voltage Unit	LED on— current parameter is voltage value	Green
	RPM (Hz+A)	Speed Unit	LED on —current parameter is rotation speed value	Green
	% (Hz+V )	Percentage	LED on—current parameter is percentage value	Green
Function LED	RUN	running status LED	LED on—in the status of running Light off—in the status of stop LED flash—in the status of sleep	Green
	L/D/C	control mode LED	LED off—in the status of keyboard control mode LED on—in the status of terminal control mode LED flash—in the status of remote communication control mode	Red
	FWD/RE V	running direction LED	LED off—in the status of forward rotation LED on—in the status of reverse rotation LED flash—the target frequency is opposite to the actual frequency or in the status of reverse-run prohibition	Red
	TUNE/T C	tuning/torque /fault LED	LED on—in the status of torque control LED flash—tuning/fault	Red

### 3.1.2. LED display

Five digits LED is able to display setup frequency, output frequency, various monitoring data and alarm code. Function codes are usually displayed as decimal digits. For example, function code F0-11 is displayed as “50.00”, means decimal digit “50”. When the function codes are displayed as hexadecimal digits, the highest bit is “H.”, means present function code value is displayed in hexadecimal way. For example, when function code F7-29 is displayed as “H.003F”, the value of F7-29 is hexadecimal number”0x3f”

The user can freely set the monitoring data of stop and running status by the function code F7-29/F7-30, all the details are showed as function code F7-29/F7-30.

### 3.1.3. Keyboard instruction

Tab.2. Keyboard function table

Key	Name	Function
<b>PRG/ESC</b>	Program/ Exit	entry or exit ,return to primary menu
	ENTER	entry into the menu interface ,confirm the setup parameters
	increase (+)	Increase in the data or function code
	decrease (-)	Decrease in the data or function code
»	shift key	Select the displayed parameters in turn on the stop display interface and running display interface, the specific content please refer to F7-29 and F7-30; when modifying parameters, select the modification digit of parameters
<b>RUN</b>	Run key	used in running operation under keyboard control mode
<b>STOP/RESET</b>	STOP/RESET	In the status of running, pressing it can stop the running operation; in fault alarm status, it can be used as reset. The characteristic of this key is limited by function code F7-02
<b>QUICK/JOG</b>	direction/jog run	When F7-28 is set as 0, it's used as jog run key. When F7-28 is set as 1, it's used as direction key, press this key now, the direction will be reversed.

### 3.2. Organization Way of the Inverter Function Code

The meaning of the function code group of M420 as follows:

Function code group	Function description	Explanation
<b>F0~FF</b>	Basic function parameter group	Compatible with M420 series of function code
<b>H0~H3</b>	2 <sup>nd</sup> motor parameter group	2 <sup>nd</sup> motor parameter, acceleration and deceleration time, control method, all can be set independently.
<b>L0~L6</b>	Enhancement function parameter group	System parameter set, custom-made user function code, optimization control, AI/AO revising, master-slave control, mechanical brake function and sleep function.
<b>N0~NF</b>	Professional inverter function selection group	Choose to use different professional inverter function
<b>U0~U1</b>	Monitoring parameter group	U0 is the fault record parameter group; U1 is the user monitoring parameter group, for the convenience to check the relevant output status.

### 3.3. Instruction of Function Code Viewing and Modification Methods

Function code parameter of M420 inverter adopts three-level menu, it can view and monitor the parameter by operation panel. The three-level menu includes function parameter set (level 1 menu) →Function code (level 2 menu) →Function code setup value (level 3 menu). Refer to Fig.4-2 for the operation procedure. In the state parameter interface, it can check the different status parameter by the “»” key.

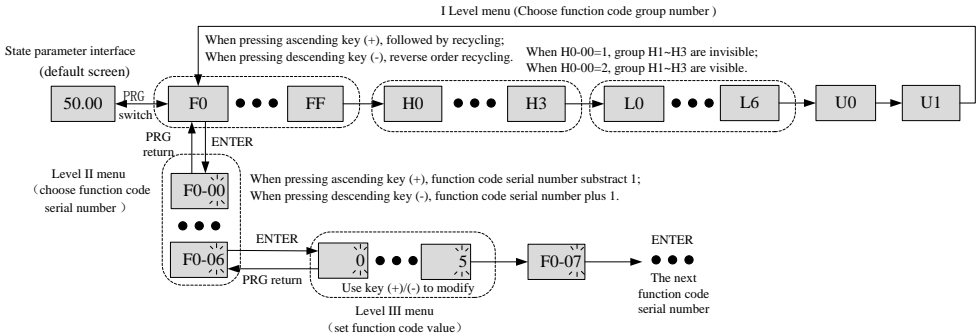

Fig.6. Three-level menu operation flow chart

Tips: When operating with the three-level menu, you can press **PRG** or **ENTER** to return to the 2<sup>nd</sup> level menu. But it will save the present parameter data and move to the next function code if press **ENTER**, while it will give up the present parameter revising if press **PRG**.

For example: make function code F1-04 change from 0.00Hz to 5.00Hz.

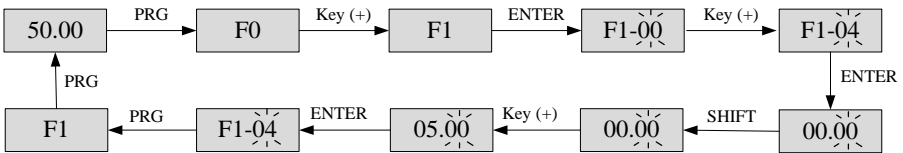

Fig.7. Parameter setting operation flowchart

In the status of the 3<sup>rd</sup> menu, the value can't be modified if the parameter doesn't have the flashing digit. You can check the function code property description for the specific reasons.

## 4. Trouble Shooting

### 4.1. Fault Warnings and Solutions

If faults happened on the running process, the inverter will stop to output immediately to protect the motor, and the corresponding fault relay of the inverter has contact action at the same time so the panel will display the fault code. The fault types and regular solutions that corresponding to the fault code are listed below in the table. Details in below form is only for reference, so please don't fix or change it by yourself. If you can't clear out the fault please contact us or the local agent for technical support.

Tab.3. Fault warning and solutions

Display	Fault Name	Possible Causes	Solutions
<b>Err01</b>	Inverter unit protection	1: The output circuit is grounded or short circuited. 2: The module overheats. 3: The internal connections become loose. 4: The main control board is faulty, drive board or module is faulty.	1: Eliminate external faults. 2: Check the air filter and the cooling fan. 3: Connect all cables properly. 4: Contact the agent or the manufacturer for help.
<b>Err04</b>	Over current during acceleration	1: The output circuit is grounded or short circuited. 2: Motor parameter is not right. 3: The acceleration time is too short. 4: Manual torque boost or V/F curve is not appropriate. 5: The voltage is too low. 6: The startup operation is performed on the rotating motor. 7: A sudden load is added during acceleration. 8: The AC drive model is of too small.	1: Eliminate external faults. 2: Perform the motor auto-tuning. 3: Increase the acceleration time. 4: Adjust the manual torque boost or V/F curve. 5: Adjust the voltage to normal range. 6: Select rotational speed tracking restart or start the motor after it stops. 7: Remove the added load. 8: Select an AC drive of higher power class.

Display	Fault Name	Possible Causes	Solutions
<b>Err05</b>	Over current during deceleration	1: The output circuit is grounded or short circuited. 2: Motor parameter is not right. 3: The deceleration time is too short. 4: The voltage is too low. 5: A sudden load is added during deceleration. 6: The braking unit and braking resistor are not installed. 7: Magnetic flux brake gain too much	1: Eliminate external faults. 2: Perform the motor auto-tuning. 3: Increase the deceleration time. 4: Adjust the voltage to normal range. 5: Remove the added load. 6: Install the braking unit and braking resistor. 7: Decrease the over-magnetic flux brake gain.
<b>Err06</b>	Over current at constant speed	1: The output circuit is grounded or short circuited. 2: Motor parameter is not right. 3: The voltage is too low. 4: A sudden load is added during operation. 5: The AC drive model is of too small.	1: Eliminate external faults. 2: Perform the motor auto-tuning. 3: Adjust the voltage to normal range. 4: Remove the added load. 5: Select an AC drive of higher power class.
<b>Err08</b>	Overvoltage during acceleration	1: The input voltage is too high. 2: An external force drives the motor during acceleration. 3: The acceleration time is too short. 4: The braking unit and braking resistor are not installed. 5: Motor parameter is wrong.	1: Adjust the voltage to normal range. 2: Cancel the external force or install a braking resistor. 3: Increase the acceleration time. 4: Install the braking unit and braking resistor. 5: Perform the motor auto-tuning.
<b>Err09</b>	Overvoltage during deceleration	1: The input voltage is too high. 2: An external force drives the motor during deceleration. 3: The deceleration time is too short. 4: The braking unit and braking resistor are not installed.	1: Adjust the voltage to normal range. 2: Cancel the external force or install a braking resistor. 3: Increase the deceleration time. 4: Install the braking unit and braking resistor.
<b>Err10</b>	Overvoltage at constant speed	1: The input voltage is too high. 2: An external force drives the motor during acceleration.	1: Adjust the voltage to normal range. 2: Cancel the external force

Display	Fault Name	Possible Causes	Solutions
			or install a braking resistor.
<b>Err12</b>	Undervoltage	<ol style="list-style-type: none"> <li>1. Instantaneous power failure occurs.</li> <li>2. The input voltage exceeds the allowed range.</li> <li>3. The DC bus voltage is too low.</li> <li>4. The rectifier bridge and Buffer resistor are faulty.</li> <li>5. The drive board is faulty.</li> <li>6. The control board is faulty.</li> </ol>	<ol style="list-style-type: none"> <li>1. Reset the fault.</li> <li>2. Adjust the input voltage to within the allowed range.</li> <li>3. Seek for maintenance.</li> </ol>
<b>Err13</b>	Drive overload	<ol style="list-style-type: none"> <li>1. The load is too heavy or the rotor is locked.</li> <li>2. The drive is of too small power class.</li> </ol>	<ol style="list-style-type: none"> <li>1: Reduce the load, or check the motor, or check the machine whether it is locking the rotor.</li> <li>2: Select a drive of higher power class.</li> </ol>
<b>Err14</b>	Motor overload	<ol style="list-style-type: none"> <li>1: F9-01istoosmall.</li> <li>2: The load is too heavy or the rotor is locked.</li> <li>3: The drive is of too small power class.</li> </ol>	<ol style="list-style-type: none"> <li>1: SetF9-01correctly.</li> <li>2: Reduce the load,or check the motor, or check the machine whether it is locking the rotor.</li> <li>3: Select a drive of higher power class.</li> </ol>
<b>Err15</b>	Drive overheat	<ol style="list-style-type: none"> <li>1: The ambient temperature is too high.</li> <li>2: The air filter is blocked.</li> <li>3: The cooling fan is damaged.</li> <li>4: The thermally sensitive resistor of the module is damaged.</li> <li>5: The inverter module is damaged.</li> </ol>	<ol style="list-style-type: none"> <li>1: Lower the ambient temperature.</li> <li>2: Clean the air filter.</li> <li>3: Replace the damaged fan.</li> <li>4: Replace the damaged thermally sensitive resistor.</li> <li>5: Replace the inverter module.</li> </ol>
<b>Err17</b>	Current detection fault	<ol style="list-style-type: none"> <li>1: The internal connections become loose.</li> <li>2: The HALL device is faulty.</li> <li>3: The control or drive board is faulty.</li> </ol>	<ol style="list-style-type: none"> <li>1: Connect all cables properly.</li> <li>2: Seek for maintenance.</li> </ol>
<b>Err20</b>	Short circuit to ground	The motor is short circuited to the ground.	Replace the cable or motor.

Display	Fault Name	Possible Causes	Solutions
<b>Err23</b>	Power input phase loss	1: The three-phase power input is abnormal. 2: The drive board is faulty. 3: The lightning board is faulty. 4: The main control board is faulty.	1: Eliminate external faults. 2: Seek for maintenance.
<b>Err24</b>	Power output phase loss	1: The cable connecting the AC drive and the motor is faulty. 2: The AC drive's three-phase outputs are unbalanced when the motor is running. 3: The drive board is faulty. 4 The module is faulty.	1: Eliminate external faults. 2: Check whether the motor three-phase winding is normal. 3: Seek for maintenance.
<b>Err25</b>	EEPROM read-write fault	The EEPROM chip is damaged.	Replace the main control board.
<b>Err27</b>	Communication fault	1: The host computer is in abnormal state. 2: The communication cable is faulty. 3: The communication parameters in group F8 are set improperly.	1: Check cabling of the host computer. 2: Check the communication cabling. 3: Set the communication parameters properly.
<b>Err28</b>	External equipment fault	External fault normally closed or normally open signal is input via DI.	Reset the fault.
<b>Err29</b>	Too large speed deviation	1: The load is too heavy and the acceleration time is too short. 2: F9-31 and F9-32 are set incorrectly.	1: Increase the acceleration and deceleration time. 2: Set F9-31 and F9-32 correctly based on the actual situation.
<b>Err30</b>	User-defined fault1	The user-defined fault 1 signal is input via DI.	Reset the fault.
<b>Err31</b>	User-defined fault2	The user-defined fault 2 signal is input via DI.	Reset the fault.
<b>Err32</b>	PID feedback lost during running	The PID feedback is lower than the setting of FA-13.	Check the PID feedback signal or set FA-26 to a proper value.

Display	Fault Name	Possible Causes	Solutions
<b>Err33</b>	Fast current limit fault	1: The load is too heavy or the rotor is locked. 2: The acceleration time is too short.	1: Reduce the load, or change the inverter with larger power. 2: Increase the acceleration time.
<b>Err34</b>	Load becoming 0	The detection is reached. Get more details form F9-28 to F9-30.	Reset the fault or reset F9-28 to F9-30 value
<b>Err35</b>	Control power supply fault	1: The input voltage is not within the allowable range. 2:The power on and off is too frequently.	1: Adjust the input voltage to the allowable range. 2:Extension of power on cycle.
<b>Err37</b>	Data storage fault	Communication between DSP and EEPROM fault.	1: Replace the main control board. 2: Contact the agent or the manufacturer for help.
<b>Err39</b>	Current running time reached	Current running time of AC driver is larger than .F7-38 value.	Reset the fault.
<b>Err40</b>	Accumulative running time reached	The accumulative running time reaches the setting value of F7-20.	Clear the record through the parameter initialization function or set F7-20 to a new value.
<b>Err42</b>	Motor switchover fault during running	Change the selection of the motor via terminal during running of the AC drive.	Perform motor switchover after the AC drive stops.
<b>Err46</b>	Master slave control communication disconnection	1:There is no set host but set the slave machine 2:The communication cable is faulty or communication parameter setting not correct.	1: Set host and reset the fault. 2: Check the communication cabling and communication parameters F8.



### 4.2. Common Faults and Treating Methods

The inverter will possibly be confront with below faults, please refer to the mentioned methods to have simple diagnosis and find the solutions.

Tab.4. Common faults and treating methods

serial number	Fault Name	Possible Causes	Solutions
1	<b>There is no display at power-on.</b>	1: There is no power supply or the power supply is too low. 2: The switching power supply on the drive board is faulty. 3: The rectifier bridge is damaged. 4: The buffer resistor of the drive is damaged. 5: The control board or the keypad is faulty. 6: The cable between the control board and the drive board or keypad breaks.	1: Check the power supply. 2: Check the bus voltage. 3: Re-connect the keypad and 30-core cables. 4: Contact the agent for technical support.
2	<b>"Err20" is displayed at power-on</b>	1: The motor or the motor output cable is short-circuited to the ground. 2: The AC driver is damage.	1: Measure the insulation of the motor and the output cable with a megger. 2: Contact the agent for technical support.
3	<b>Err15 (module overheat) fault is reported frequently.</b>	1: The setting of carrier frequency is too high. 2: The cooling fan is damaged, or the air filter is blocked. 3: Components inside the AC drive are damaged (thermal coupler or others).	1: Reduce the carrier frequency (F0-26). 2: Replace the fan and clean the air filter. 3: Contact the agent for technical support.
4	<b>The motor does not rotate after the AC drive runs.</b>	1: Check the motor and the motor cables. 2: The AC drive parameters are set improperly (motor parameters). 3: The cable between the drive board and the control board is in poor contact. 4: The drive board is faulty.	1: Ensure the cable between the AC drive and the motor is normal. 2: Replace the motor or clear mechanical faults. 3: Check and re-set motor parameters.

serial number	Fault Name	Possible Causes	Solutions
5	<b>The DI terminals are disabled.</b>	1: The parameters are set incorrectly. 2: The external signal is incorrect. 3: Wrong location of the DI dial switch. 4: The control board is faulty.	1: Check and reset the parameters in group F5. 2: Re-connect the external signal cables. 3. Wrong location of the DI dial switch. 4: Contact the agent for technical support.
6	<b>The AC drive reports over-current and over-voltage frequently</b>	1: The motor parameters are set improperly. 2: The acceleration/deceleration time is improper. 3: The load fluctuates.	1: Re-set motor parameters or re-perform the motor auto-tuning. 2: Set proper acceleration/deceleration time. 3: Contact the agent for technical support.

## 5. Function code table

The symbols in the function code table are described as follows:

"☆":The parameter can be modified when the AC drive is in either stop or running state.

"★":The parameter cannot be modified when the AC drive is in the running state.

"○":The parameter is the actually measured value and cannot be modified.

"●":The parameter is factory parameter and can be set only by the manufacturer

Enhancement code: group H0~group H3, group L0~group L3, are started by function code parameter F7-75.

Function Code	Parameter Name	Setting Range	Default	Property
Group F0: Standard Function Parameters				
F0-00	Drive model	Drive model: 5 digital display, 2 decimal point	53#.#	●
F0-01	0: for general purpose 1: for pump application	0: for general purpose 1: for pump application	0	●
F0-02	Rated driver current	0.1A to 3000.0A	Model dependent	●
F0-03	Control mode	1: Sensor-less flux vector control (SFVC). 2: Voltage/Frequency (V/F) control.	2	★
F0-04	Running command source selection	0: Operation keypad control (LED off). 1: Terminal control (LED on). 2: Communication control (LED blinking).	0	★
F0-05	Base frequency for modification during running	0: Running frequency. 1: Set frequency.	0	★
F0-06	Main frequency source X selection	0: UP/ DOWN setting (non-recorded after stop). 1: UP/ DOWN setting (retentive after stop). 2: AI1 3: AI2 4: Multi-speed. 5: Simple PLC. 6: PID 7: Communication setting. 8: Pulse setting.	1	★
F0-07	Auxiliary frequency source Y selection	0: UP/ DOWN setting (Speed reset after stop). 1: UP/ DOWN setting	0	★

Function Code	Parameter Name	Setting Range	Default	Property
		(Retentive after stop). 2: AI1 3: AI2 4: Multi-reference. 5: Simple PLC. 6: PID 7: Communication setting. 8: Pulse setting.		
F0-08	Range of auxiliary frequency Y selection	0: Relative to maximum frequency. 1: Relative to main frequency X.	0	☆
F0-09	Range of auxiliary frequency Y	0% ~ 100%	100%	☆
F0-10	Frequency source selection	Unit's digit (Frequency source selection). 0: Main frequency source X. 1: X and Y operation result. 2: Switchover between X and Y (by DI terminal). 3: Switchover between X and "X and Y superposition" (by DI terminal). 4: Switchover between Y and "X and Y superposition" (by DI terminal). Ten's digit() 0: X+Y 1: X-Y 2: Max(X,Y) 3: Min(X,Y)	00	☆
F0-11	Preset frequency	0.00 to maximum frequency F0-14.	50.00Hz	☆

Function Code	Parameter Name	Setting Range	Default	Property
F0-13	Rotation direction	0: Same direction 1: Reverse direction 2: Reverse forbidden	0	☆
F0-14	Maximum output frequency	50.0Hz–1200.0 Hz(F0-20=1) 50.0Hz–600.00 Hz(F0-20=2)	50.00Hz	★
F0-15	Frequency source upper limit	0: Set by F0-16 1: AI1 2: AI2 3: Communication setting 4: Pulse setting	0	★
F0-16	Frequency upper limit	Frequency lower limit(F0-18)to maximum frequency (F0-14)	50.0Hz	☆
F0-17	Frequency upper limit offset	0.00 Hz to maximum frequency (F0-14).	0.00Hz	☆
F0-18	Frequency lower limit	0.00 Hz to frequency upper limits (F0-16).	0.00Hz	☆

Function Code	Parameter Name	Setting Range	Default	Property
F0-19	Command source binding select	Unit's digit: Binding operation keypad command to frequency source. 0: No Binding 1: Digital setting 2: AI1 3: AI2 4: Multi-speed 5: Simple PLC 6: PID 7: Communication setting. 8: Pulse setting(HDI5). Ten's digit: Binding operation terminal command to frequency source. Hundred's digit: Binding operation communication command to frequency source. Thousand's digit: Reserved.	000	☆
F0-20	Frequency fractional selection	1: 0.1Hz 2: 0.01Hz	2	★
F0-21	Acceleration/Deceleration time unit	0: 1s 1: 0.1s 2: 0.01s	1	★
F0-22	Acceleration/Deceleration time base frequency	0: Maximum frequency (F0-14) 1: Set frequency 2: Rated motor frequency	0	★
F0-23	Acceleration time 1	0s~30000s (F0-21 = 0) 0.0s~3000.0s (F0-21 = 1) 0.00s~300.00s (F0-21 = 2)	10.0s	☆
F0-24	Deceleration time 1	0s~30000s (F0-21 = 0) 0.0s~3000.0s (F0-21 = 1)	10.0s	☆

Function Code	Parameter Name	Setting Range	Default	Property
		0.00s~300.00s (F0-21 = 2)		
F0-25	Over modulation voltage boost	0% to 10%	3%	★
F0-26	Carrier frequency	0.5kHz~16.0kHz	Model dependent	☆
F0-27	Carrier frequency adjustment with temperature	0: No 1: Yes	1	☆
F0-28	Initialization parameters	0:No operation. 1:Restore factory parameters, except motor parameters, record information and F0-20. 2:Clear the record information. 3:Backup the current user parameters. 4:User parameter backup recovery.	0	★
<b>Group F1: Start/ Stop Control</b>				
F1-00	Start mode	0: Direct start. 1: Rotational speed tracking restart. 2: Pre-excited start(asynchronous motor).	0	☆
F1-01	Rotational speed tracking mode	0: From frequency at stop 1: From zero speed 2: From maximum frequency	0	★
F1-02	Max current of rotational speed tracking	30% ~ 180%	100%	★
F1-03	Rotational speed tracking speed	1~100	20	☆
F1-04	Startup frequency	0.00Hz~10.00Hz	0.00Hz	☆
F1-05	Startup frequency holding	0.0s~100.0s	0.0s	★



Function Code	Parameter Name	Setting Range	Default	Property
	time			
F1-06	Startup DC braking current/ Pre-excited current	0% ~ 100%	0%	★
F1-07	Startup DC braking time/ Pre-excited time	0.0s ~ 100.0s	0.0s	★
F1-08	Acceleration/Deceleration mode	0: Linear 1: S-curve	0	★
F1-09	Acceleration time proportion of S-curve start segment	0.00% ~ 80.00%	20.00%	★
F1-10	Deceleration time proportion of S-curve start segment	0.00% ~ 80.00%	20.00%	★
F1-11	Acceleration time proportion of S-curve end segment	0.00% ~ 80.00%	20.00%	★
F1-12	Deceleration time proportion of S-curve end segment	0.00% ~ 80.00%	20.00%	★
F1-13	Stop mode	0: Decelerate to stop 1: Coast to stop	0	☆
F1-14	Initial frequency of stop DC braking	0.00HZ ~ maximum frequency (F0-14)	0.00Hz	☆
F1-15	Waiting time of stop DC braking	0.0s ~ 100.0s	0.0s	☆
F1-16	Stop DC braking current	0% ~ 100%	0%	☆
F1-17	Stop DC braking time	0.0s ~ 36.0s	0.0s	☆
F1-21	Demagnetization time	0.01s ~ 3.00s	0.50s	★
F1-23	Nonstop at instantaneous stop (when power fail) mode selection	0: Ineffective 1: Automatic start at power fluctuation	0	★

Function Code	Parameter Name	Setting Range	Default	Property
		2: Decelerate to stop.		
F1-24	Deceleration time of nonstop at instantaneous stop	0.0s to 100.0s	10.0s	★
F1-25	Effective voltage of nonstop at instantaneous stop	60% to 85%	80%	★
F1-26	Recovery voltage of nonstop at instantaneous stop	85% to 100%	90%	★
F1-27	Detection time of instantaneous stop nonstop recovery voltage	0.0s to 300.0s	0.3s	★
F1-28	Auto-regulation gain of nonstop at instantaneous stop	0 to 100	40	☆
F1-29	Auto-regulation integral time of nonstop at instantaneous stop	1 to 100	20	☆
Group F2:V/F Control Parameters				
F2-00	V/F curve setting	0: Linear V/F. 1: Multi-point V/F. 2: Square V/F. 3: 1.7-power V/F. 4: 1.5-power V/F. 5: 1.3-power V/F. 6: Voltage and frequency complete separation. 7: Voltage and frequency half separation.	0	★
F2-01	Torque boost	0.0% ~ 30.0%	0.0%	☆
F2-02	Cut-off frequency of torque boost	0.00 Hz to maximum output frequency (F0-14).	25.00Hz	★

Function Code	Parameter Name	Setting Range	Default	Property
F2-03	Multi-point V/F frequency 1 (F1)	0.00Hz to F2-05	3.00Hz	★
F2-04	Multi-point V/F voltage 1 (V1)	0.0% to 100.0%	8.0%	★
F2-05	Multi-point V/F frequency 2 (F2)	F0-05 to F2-07	10.00Hz	★
F2-06	Multi-point V/F voltage 2 (V2)	0.0% to 100.0%	20.0%	★
F2-07	Multi-point V/F frequency 3 (F3)	0.00Hz to 50.00Hz	50.00Hz	★
F2-08	Multi-point V/F voltage 3 (V3)	0.0% to 100.0%	100.0%	★
F2-09	Slip compensation ratio	0.0% to 200.0%	50.0%	☆
F2-10	Over-excitation gain	0 to 200	100	☆
F2-11	Oscillation suppression gain	0 to 100	Model dependent	☆
F2-13	Slip compensation time	0.02s to 1.00s	0.30s	☆
F2-15	Output voltage source for voltage and frequency separation	0: Digital setting (F2-16). 1: AI1                    2: AI2 3: Multi-reference 4: Simple PLC    5: PID 6: Communication setting. 7: Pulse setting (DI5). 100.0% corresponds to the rated.	0	☆
F2-16	Voltage digital setting for V/F separation	0 V to rated motor voltage	0V	☆
F2-17	Voltage rise time of V/F separation	0.0s to 3000.0s	1.0s	☆
F2-18	Voltage decline time of	0.0s to 3000.0s	1.0s	☆

Function Code	Parameter Name	Setting Range	Default	Property
	V/F separation			
F2-19	Stop mode selection upon V/F separation	0: Frequency and voltage declining independently. 1: Frequency declining after voltage declines to 0.	0	☆
Group F3: Vector Control Parameters				
F3-00	Switchover frequency 1	1.00Hz to F3-02	5.00Hz	☆
F3-02	Switchover frequency 2	F3-00 to F0-14	10.00Hz	☆
F3-04	Speed loop proportional gain at low frequency	1.0 to 10.0	4.0	☆
F3-05	Speed loop integral time at low frequency	0.01s to 10.00s	0.50s	☆
F3-06	Speed loop proportional gain at high frequency	1.0 to 10.0	2.0	☆
F3-07	Speed loop integral time at high frequency	0.01s to 10.00s	1.00s	☆
F3-08	Speed loop integral property	0: Integral take effect 1: Integral separation	0	★
F3-11	Torque adjustment proportional gain Kp	0 to 30000	2200	☆
F3-12	Torque adjustment integral gain Ki	0 to 30000	1500	☆
F3-13	Excitation adjustment proportional gain Kp	0 to 30000	2200	☆
F3-14	Excitation adjustment integral gain Ki	0 to 30000	1500	☆
F3-15	Flux braking gain	0 to 200	0	☆
F3-16	Field weakening torque correction ratio	50% to 200%	100%	☆
F3-17	Slip compensation gain	50% to 200%	100%	☆

Function Code	Parameter Name	Setting Range	Default	Property
F3-18	Speed loop feedback filter time	0.000s to 1.000s	0.015s	☆
F3-19	Speed loop output filter time	0.000s to 1.000s	0.000s	☆
F3-20	Source of power-driven torque upper limit	0: F3-21 1: AI1            2: AI2 3: Communication setting 4: Pulse setting (DI5) (Analog range corresponds to F3-21)	0	☆
F3-21	Power-driven torque upper limit	0.0% to 200.0%	150.0%	☆
F3-22	Upper limit source of braking torque	0: F3-23 1: AI1            2: AI2 3: Communication setting 4: Pulse setting (DI5) (Analog range corresponds to F3-23)	0	☆
F3-23	Braking torque upper limit	0.0% to 200.0%	150.0%	☆
<b>Group F4: Motor 1 Parameters</b>				
F4-00	Auto-tuning selection	0: No auto-tuning 1: Static auto-tuning 2: Complete auto-tuning	0	★
F4-01	Rated motor 1 power	0.1kW to 1000.0kW	Model dependent	★
F4-02	Rated motor 1 voltage	0V to 1500V	380	★
F4-03	Number of pole pairs of motor 1	2 to 64	Model dependent	○
F4-04	Rated motor 1 current	0.01A to 600.00 A (motor rated power ≤30 kW).	F4-01 dependent	★

Function Code	Parameter Name	Setting Range	Default	Property
		0.1A to 6000.0 A (motor rated power >30kW).		
F4-05	Rated motor frequency	0.01Hz to F0-14	50.00Hz	★
F4-06	Rated motor 1 rotational speed	0rpm to 60000rpm	F4-01 dependent	★
F4-07	Motor 1 no-load current	0.01A to F4-04 A (motor rated power ≤30 kW). 0.1A to F4-04 A (motor rated power >30kW).	Model dependent	★
F4-08	Motor 1 stator resistance	0.001Ωto 65.535Ω	Model dependent	★
F4-09	Motor 1 rotor resistance	0.001Ωto 65.535Ω	Model dependent	★
F4-10	Motor 1 mutual inductive	0.1mH to 6553.5mH	Model dependent	★
F4-11	Motor 1 leakage inductive	0.01mH to 655.35mH	Model dependent	★
F4-12	Acceleration time of complete auto-tuning	1.0s to 6000.0s	10.0s	☆
F4-13	Deceleration time of complete auto-tuning	1.0s to 6000.0s	10.0s	☆
<b>Group F5: Input Terminals</b>				
F5-00	DI1 function selection	0: No function	1	★
F5-01	DI2 function selection	1: Forward RUN (FWD) 2: Reverse RUN (REV)	2	★
F5-02	DI3function selection	3: Three-wire control	9	★
F5-03	DI4 function selection	4: Forward JOG (FJOG) 5: Reverse JOG (RJOG)	12	★
F5-04	DI5 function selection	6: Speed increase	13	★

Function Code	Parameter Name	Setting Range	Default	Property
F5-05	DI6 function selection	7: Speed Decrease 8: Coast to stop 9: Fault reset (RESET) 10: RUN pause 11 : External fault normally open (NO) input. 12: Constant speed 1 13: Constant speed 2	13	★
F5-06	DI7 function selection	14: Constant speed 3 15: Constant speed 4 16: Terminal 1 for acceleration/	13	★

Function Code	Parameter Name	Setting Range	Default	Property
		deceleration time selection 17: DI for acceleration/ deceleration time selection 18 : Frequency source switchover 19 : MOTPOT setting clear (terminal, keypad) 20 : Command source switchover terminal 1 21 : Acceleration/Deceleration prohibited 22: PID pause 23: PLC status reset 24: Swing pause 25: Timer trigger input 26: Immediate DC injection braking 27: External fault normally closed (NC) input 28: Counter input 29: Counter reset 30: Length count input 31: Length reset 32: Torque control prohibited. 33 : Pulse input (enabledonlyforDI5). 34 : Frequency modification forbidden. 35 : PID action direction reverse. 36: ExternalSTOPterminal1. 37 : Command source switchover terminal 2 38: PID integral disabled 39: Switchover between main		



Function Code	Parameter Name	Setting Range	Default	Property
		frequency source X and preset frequency 40: Switchover between auxiliary frequency source Y and preset frequency 41: Switchover between motor 1 and motor 2 42: Reserved 43: PID parameter switchover 44 : Speed control/Torque control switchover 45: Emergency stop 46: External STOP terminal 2 47: Deceleration DC injection braking 48: Clear the current running time 49 : Switchover between two-line mode and three-line mode 50: Reverse run prohibited 51: User- defined fault 1 52: User-defined fault 2 53: Dormant input		
F5-10	DI filter time	0.000 to 1.000s	0.010s	☆
F5-11	Terminal command mode	0: Two-line mode 1 1: Two-line mode 2 2: Three-line mode 1 3: Three-line mode 2	0	★
F5-12	Terminal UP/DOWN rate	0.01Hz/s to 100.00Hz/s	1.00Hz/s	☆
F5-13	Terminal effective mode 1	0: High level 1: Low level	00000	★

Function Code	Parameter Name	Setting Range	Default	Property
		Unit's:DI1; Ten's:DI2; Hundred's:DI3; Kilobit:DI4; Myriabit:DI5		
F5-15	AI1 minimum input	0.00V to 10.00V	0.00V	☆
F5-16	Corresponding setting of AI1 minimum input	-100.0% to 100.00%	0.0%	☆
F5-17	AI1 maximum input	0.00V to 10.00V	10.00V	☆
F5-18	Corresponding setting of AI1 maximum	-100.0% to 100.00%	100.0%	☆
F5-19	AI1 filter time	0.00s to 10.00s	0.10s	☆
F5-20	AI2 minimum input	0.00V to 10.00V	0.00V	☆
F5-21	Corresponding setting of AI2 minimum input	-100.0% to 100.00%	0.0%	☆
F5-22	AI2 maximum input	0.00V to 10.00V	10.00V	☆
F5-23	Corresponding setting of AI2 maximum	-100.0% to 100.00%	100.0%	☆
F5-24	AI2 filter time	0.00s to 10.00s	0.10s	☆
F5-30	Pulse minimum input	0.00KHz to 50.00KHz	0.00KHz	☆
F5-31	Corresponding setting of pulse minimum input	-100.0% to 100.00%	0.0%	☆
F5-32	Pulse maximum input	0.00KHz to 50.00KHz	50.00KHz	☆
F5-33	Corresponding setting of pulse maximum input	-100.0% to 100.00%	0.0%	☆
F5-34	Pulse filter time	0.00s to 10.00s	0.10s	☆
F5-35	DI1 On delay time	0.0s to 3600.0s	0.0s	☆
F5-36	DI1 Off delay time	0.0s to 3600.0s	0.0s	☆

Function Code	Parameter Name	Setting Range	Default	Property
F5-37	DI2 On delay time	0.0s to 3600.0s	0.0s	☆
F5-38	DI2 Off delay time	0.0s to 3600.0s	0.0s	☆
F5-39	DI3 On delay time	0.0s to 3600.0s	0.0s	☆
F5-40	DI3 Off delay time	0.0s to 3600.0s	0.0s	☆
F5-41	AI1 function selection as DI terminal	0 to 53 as DI terminal function.	0	★
F5-42	AI2 function selection as DI terminal	0 to 53 as DI terminal function.	0	★
F5-44	AI effective mode selection as DI terminal	Unit's digit(AI1). 0: High level effective. 1: Low level effective. Ten's digit(AI2). 0: High level effective. 1: Low level effective. Hundred's digit::reserved	00	☆
F5-45	AI curve selection	Unit's digit (AI1 curve selection) 0: 2 points curve. 1: Multi-point curve 1. 2: Multi-point curve 2. Ten's digit (AI2 curve selection). 0: 2 points curve 1: Multi-point curve 1 2: Multi-point curve 2 Hundred's digit: reserved	00	☆
F5-46	AI Signal input type selection	Unit's digit:AI1; Ten's digit:AI2	00	☆

Function Code	Parameter Name	Setting Range	Default	Property
		0:Voltage style 1:Current style		
Group F6: Output Terminals				
F6-00	Relay 1 function	0: No output	2	☆
F6-01	Relay 2 function	1: AC drive running 2: Fault output	1	☆
F6-02	Y1 function	3: Frequency-level detection FDT1 reached 4: Frequency reached 5: Zero-speed running (no output at stop) 6: Motor overload pre-warning 7: AC drive overload pre-warning 8: PLC cycle completed 9: Accumulative running time reached 10: Frequency limited 11: Ready for RUN 12: AI1>AI2 13: Frequency upper limit reached 14: Frequency lower limit reached 15: Undervoltage state output 16: Communication setting 17: Timer output 18: Reverse running 19: Reserved 20: Length reached 21: Torque limited 22: Current 1 reached	1	☆

Function Code	Parameter Name	Setting Range	Default	Property
		23: Frequency 1 reached 24: Module temperature reached 25: Load lost 26: Accumulative power-on time reached 27: Clacking reached output 28: Current running time reached 29: Set count value reached 30: Designated count value reached 31: Motor 1 and motor 2 indication 32: Brake control output 33: Zero-speed running 2 (having output at stop) 34: Frequency level detection FDT2 output 35: Zero current state 36: Software over current 37: Frequency lower limit reached (having output at stop) 38: Alarm output 39: Reserved 40: All input overrun 41: Reserved 42: Reserved 43: Frequency 2 reached 44: Current 2 reached 45: Fault output		
F6-04	FM terminal output selection	0: pulse output (FMP) 1: open loop collector switch value output (FMR)	0	☆

Function Code	Parameter Name	Setting Range	Default	Property
F6-05	FMR output selection	Same as Y1 output selection	0	☆
F6-09	AO1 output function selection	0: Running frequency 1: Set frequency 2: Output current	0	☆
F6-10	AO2 output function selection	3: Output power 4: Output voltage	0	☆
F6-11	FMP output function selection	5: Analog AI1 input 6: Analog AI2 input 7: Communication setting 8: Output torque 9: Length 10: Count value 11: Motor rotational speed 12: Output bus voltage(0 to 3 times of driver rated) 13: Pulse input 14: Output current 15: Output voltage(100.0% corresponds to 1000.0V) 16: Output torque (Actual value: -2 to +2 times of the rated value.	0	☆
F6-12	FMP output max-frequency	0.01KHz~100.00KHz	50.00	☆
F6-13	AO1 minimum output	-100.0% to F6-15	0.0%	☆
F6-14	Minimum corresponds to AO1 output	0.00V to 10.00V	0.00v	☆
F6-15	AO1 maximum output	F6-13 to 100.0%	100.0%	☆
F6-16	Maximum corresponds to AO1 output	0.00V to 10.00V	10.00V	☆
F6-17	AO2 minimum output	-100.0% to F6-19	0.0%	☆

Function Code	Parameter Name	Setting Range	Default	Property
F6-18	Minimum corresponds to AO2 output	0.00V to 10.00V	0.00v	☆
F6-19	AO2 maximum output	F6-17 to 100.0%	100.0%	☆
F6-20	Maximum corresponds to AO2 output	0.00V to 10.00V	10.00V	☆
F6-26	Relay 1 output delay	0.0s to 3600.0s	0.0s	☆
F6-27	Relay 2 output delay	0.0s to 3600.0s	0.0s	☆
F6-28	Y1 high level output delay	0.0s to 3600.0s	0.0s	☆
<b>Group F7: Auxiliary Functions and Keypad Display</b>				
F7-00	JOG running frequency	0.00 Hz to maximum frequency	6.00Hz	☆
F7-01	JOG acceleration time	0.0s to 3000.0s	10.0s	☆
F7-02	JOG deceleration time	0.0s to 3000.0s	10.0s	☆
F7-03	Acceleration time 2	0.0s to 3000.0s	10.0s	☆
F7-04	Deceleration time 2	0.0s to 3000.0s	10.0s	☆
F7-05	Acceleration time 3	0.0s to 3000.0s	10.0s	☆
F7-06	Deceleration time 3	0.0s to 3000.0s	10.0s	☆
F7-07	Acceleration time 4	0.0s to 3000.0s	10.0s	☆
F7-08	Deceleration time 4	0.0s to 3000.0s	10.0s	☆
F7-09	Jump frequency 1	0.00 Hz to maximum frequency	0.00Hz	☆
F7-10	Jump frequency 1 amplitude.	0.00 Hz to maximum frequency	0.00Hz	☆
F7-11	Jump frequency 2	0.00 Hz to maximum frequency	0.00Hz	☆
F7-12	Jump frequency 2 amplitude.	0.00 Hz to maximum frequency	0.00Hz	☆
F7-15	Forward/Reverse rotation dead-zone time.	0.0s to 3000.0s	0.0s	☆

Function Code	Parameter Name	Setting Range	Default	Property
F7-16	Keypad knob accuracy	0: Default mode 1: 0.1Hz    2: 0.5Hz 3: 1Hz      4: 2Hz 5: 4Hz      6: 5Hz 7: 8Hz      8: 10Hz	0	☆
F7-17	Running mode when set frequency lower than frequency lower limit.	0: Run at frequency lower limit 1: Stop 2: Run at zero speed	0	☆
F7-18	Droop ration	0.0% to 100.0%	0.0%	☆
F7-19	Delay time of stopping mode when set frequency lower than frequency lower limit.	0.0s to 600.0s	0.0s	☆
F7-20	Setting accumulative running time.	0h to 65000h	0h	☆
F7-21	JOG preferred	0: Disable 1: Enable	1	☆
F7-22	Frequency detection value (FDT1)	0.00 Hz to maximum frequency	50.00Hz	☆
F7-23	Frequency detection hysteresis (FDT hysteresis 1)	0.0% to 100.0%	5.0%	☆
F7-24	Detection range of frequency reached	0.0% to 100.0%	0.0%	☆
F7-25	Reserved		0	●
F7-26	Cooling fan control	0: Fan working continuously. 1: Fan working during running (Fan working after stopping when temperature is higher than 40°C)	0	★
F7-27	STOP/RESET key function	0: STOP/RESET key enabled only in operation keypad control.	1	☆



Function Code	Parameter Name	Setting Range	Default	Property
		1: STOP/RESET key enabled in any operation mode.		
F7-28	Quick/JOG function selection	0: Forward JOG. 1: Switchover between forward rotation and reverse rotation. 2: Reverse JOG. 3: Switchover between operation keypad control and remote command control.	0	★
F7-29	LED display running parameters	0000 to 0xffff Bit00: Running frequency 0001 Bit01: Set frequency 0002 Bit02: Bus voltage (V) 0004 Bit03: Output voltage 0008 Bit04: Output current 0010 Bit05: Output power (kW) 0020 Bit06: DI input status 0040 Bit07: DO output status 0080 Bit08: AI1 voltage (V) 0100 Bit09: AI2 voltage (V) 0200 Bit10: PID setting 0400 Bit11: PID feedback 0800 Bit12: Count value 1000 Bit13: Length value 2000 Bit14: load speed display 4000 Bit15: PLC stage 8000	H.401f	☆

Function Code	Parameter Name	Setting Range	Default	Property
F7-30	LED display stop parameters	1 to 0xffff Bit00: Set frequency 0001 Bit01: Bus voltage (V) 0002 Bit02: DI input status 0004 Bit03: DO output status 0008 Bit04: AI1 voltage (V) 0010 Bit05: AI2 voltage (V) 0020 Bit06: PID setting 0040 Bit07: PID feedback 0080 Bit08: Count value 0100 Bit09: Length value 0200 Bit10: Load speed display 0400 Bit11: PLC stage 0800 Bit12: Pulse input frequency 1000 Bit13~Bit15: Reserved	H.0003	☆
F7-31	Load speed display coefficient	0.001 to 65.500	1.000	☆
F7-32	Temperature of inverter module	12°C to 100°C	Measured value	●
F7-33	Accumulative power-on time	0h to 65535h	Measured value	●
F7-34	Accumulative running time	0h to 65535h	Measured value	●
F7-36	Current running time function	0: Disable 1: Enable:	0	★
F7-37	Current running time source	0: Digital setting F7-38 1: AI1 2: AI2 (100% of analog input corresponds to F8-44)	0	★

Function Code	Parameter Name	Setting Range	Default	Property
F7-38	Setting of current running time	0.0min to 6500.0min	0.0min	☆
F7-39	High level timing	0.0s to 6000.0s	2.0s	☆
F7-40	Low level timing	0.0s to 6000.0s	2.0s	☆
F7-41	Startup protection	0: No 1: Yes	1	☆
F7-43	Frequency reached detection value 1	0.00Hz to F0-14	50.00Hz	☆
F7-44	Frequency reached detection duration 1	0% to 100%	0%	☆
F7-45	Current detection level 1	0% to 300%	100%	☆
F7-46	Current reached detection duration 1	0% to 300%	0%	☆
F7-49	User code	0 to 65535	0	☆
F7-50	Jump frequency during acceleration and deceleration	0:Disable 1:Enable	0	☆
F7-51	Setting power-on reached time	0h to 65530h	0h	☆
F7-53	Frequency switchover point between acceleration time 1 and acceleration time 2	0.00Hz to maximum frequency(F0-14)	0.00Hz	☆
F7-54	Frequency switchover point between deceleration time 1 and deceleration time 2	0.00Hz to maximum frequency(F0-14)	0.00Hz	☆
F7-55	Frequency detection value (FDT2)	0.00 Hz to maximum frequency	50.00Hz	☆
F7-56	Frequency detectFDT2 hysteresis value	0.0% to 100.0%	5.0%	☆

Function Code	Parameter Name	Setting Range	Default	Property
F7-57	Frequency reached detection value 2	0.00Hz to F0-14	50.00Hz	☆
F7-58	Frequency reached detection duration 2	0% to 100%	0%	☆
F7-59	Zero current detection level	0% to 300%	10.0%	☆
F7-60	Zero current detection delay time	0% to 300%	1.0s	☆
F7-61	Current output detection amplitude	20.0% to 400.0%	200.0%	☆
F7-62	Current output detection amplitude delay time	0.00s to 300.00s	0.00s	☆
F7-63	Current detection level 2	20% to 300%	100%	☆
F7-64	Current reached detection duration 2	0.0% to 300.0%	0.0%	☆
F7-65	LED display running parameters 2	1 to 0xffff Bit00: target torque 0001 Bit01: output torque 0002 Bit02: pulse input frequency (KHz) 0004 Bit03: HDI input liner speed(m/min) 0008 Bit04: motor rotation speed0010 Bit05: AC line current 0020 Bit06~Bit15: reserved	0	☆
F7-67	A11 input voltage lower limit	0.00V to F7-68	2.00V	☆
F7-68	A11 input voltage upper limit	F7-67 to 11.00V	8.00V	☆

Function Code	Parameter Name	Setting Range	Default	Property
F7-69	Module temperature threshold	0°C to 90°C	70°C	☆
F7-70	Output power correction coefficient	0.001 to 3.000	1.000	☆
F7-71	Linear speed display coefficient	Linear speed = F-71 * HDI1 pulse number per second / Fb-07	1.000	☆
F7-72	Accumulative power consumption	0kW to 65535kW	Measured value	●
F7-73	Performance software version		##	●
F7-74	Function software version		##	●
F7-75	Improve function parameter display selecting	0: Hide improvement function parameter: H0~H3, L0~L5 1: Display improvement function parameter: H0~H3, L0~L5	0	☆
<b>Group F8: Communication Parameters</b>				
F8-00	Baud rate	0: 300BPS 1: 600BPS 2: 1200BPS 3: 2400BPS 4: 4800BPS 5: 9600BPS 6: 19200BPS 7: 38400BPS	5	☆
F8-01	Data format	0: No check <8,N,2> 1: Even parity check 2 <8,E,1> 2: Odd Parity check <8,O,1> 3: No check1 <8,N,1>	0	☆

Function Code	Parameter Name	Setting Range	Default	Property
F8-02	Local address	0 to 247 (0 is Broadcast address)	1	☆
F8-03	Response delay	0ms to 30ms	2ms	☆
F8-04	Communication timeout	0.0s to 30.0s	0.0s	☆
F8-05	Communication data format selection	0: Standard MODBUS-RTU protocol 1: Nonstandard MODBUS-RTU protocol	0	☆
<b>Group F9: Fault and Protection</b>				
F9-00	Motor overload protection selection.	0: Disable 1: Enable	1	☆
F9-01	Motor overload protection gain.	0.02 to 10.00	1.00	☆
F9-02	Motor overload warning coefficient.	50% to 100%	80%	☆
F9-03	Overvoltage stall gain	0 to 100	30	☆
F9-04	Overvoltage stall protective voltage	200.0V to 800.0V	760.0V	★
F9-05	V/F overcurrent stall gain	0 to 100	20	☆
F9-06	V/F overcurrent stall protective current	100% to 200%	150%	★
F9-07	VF weak magnetic current stall protection coefficient.	50% to 200%	100%	★
F9-08	Overvoltage stalling allowed to rise limit value	0% to 100%	10%	☆
F9-11	Fault auto reset times	0 to 20	0	☆
F9-12	Fault relay action selection during fault auto reset	0: Not act 1: Act	0	☆
F9-13	Time interval of fault auto reset	0.1s to 100.0s	1.0s	☆

Function Code	Parameter Name	Setting Range	Default	Property
F9-14	Input phase loss protection selection	0: Disable 1: Enable	1	☆
F9-15	Output phase loss protection selection	0: Disable 1: Enable	1	☆
F9-16	Short-circuit to ground upon power-on	0: Disable 1: Enable	1	☆
F9-17	Undervoltage fault auto reset selection	0: Manual reset fault after the under voltage fault. 1: Auto reset fault according to the bus voltage after the fault.	0	☆
F9-18	Overvoltage inhibition mode selection	0: Ineffective 1: Overvoltage inhibition mode 1 2: Overvoltage inhibition mode 2	1	★
F9-19	Over excitation force state selection	0: Ineffective 1: Effective during running at constant speed or deceleration 2: Effective during running at deceleration	2	★
F9-20	Threshold of over-voltage inhibition mode 2	1.0% to 150.0%	100.0%	★
F9-22	Fault protection action selection 1	0 to 22202 Unit's digit: Motor over load – Err14 0: Coast to stop 1: Stop according to stop mode 2: Continue to run Ten's digit: Reserved Hundred's digit: Input phase loss - Err23 Thousand's digit: Output phase loss - Err24 Ten thousand's digit: Parameter read-write fault – Err25	00000	☆

Function Code	Parameter Name	Setting Range	Default	Property
F9-23	Fault protection action selection 2	0 to 22222 Unit's digit: Communication fault – Err27 0: Coast to stop 1: Stop according to stop mode 2:Continue to run Ten's digit: External equipment fault – Err28 Hundred's digit: Too large speed deviation – Err29 Thousand's digit: User-definedfault1 – Err30 Ten thousand's digit: User-definedfault1 – Err31	00000	☆
F9-24	Fault protection action selection 3	0 to 22022 Unit's digit: PID feedback lost during running – Err32 0: Coast to stop 1: Stop according to stop mode 2:Continue to run Ten's digit: Load becoming 0 – Err34 Unit's place: PID feedback losing on running-Err32 0:free stop 1:stop according to stop mode 2:keep running Ten's place: off load fault Hundreds place: reserved Thousands place: Current running time reached – Err39 Ten thousand's digit: Accumulative running time reached – Err40	00000	☆



Function Code	Parameter Name	Setting Range	Default	Property
F9-26	Frequency selection for continuing to run upon fault	0: Current running frequency 1: Set frequency 2: Frequency upper limit 3: Frequency lower limit 4: Backup frequency(F9-27)	1	☆
F9-27	Backup frequency upon abnormality	0.0% to 100.0%	100.0%	☆
F9-28	Protection upon load becoming 0	0: Disable 1: Enable	0	☆
F9-29	Detection level of load becoming 0	0.0% to 80.0%	20.0%	★
F9-30	Detection time of load becoming 0	0.0s to 100.0s	5.0%	☆
F9-31	Detection value of too large speed deviation	0.0% to 100.0%	20.0%	☆
F9-32	Detection time of too large speed deviation	0.0s to 100.0s	0.0s	☆
F9-33	Over-speed detection value	0.0% to 100.0%	20.0%	☆
F9-34	Over-speed detection time	0.0s to 100.0s	2.0s	☆
F9-35	Motor overload protection current coefficient	100% to 200%	100%	☆
<b>Group FA: PID Function</b>				
FA-00	PID setting source	0: Keypad 1: AI1 2: AI2 3: Communication setting 4: Pulse setting (DI5) 5: Multi-reference	0	☆
FA-01	PID digital setting	0.0% to 100.0%	50.0%	☆

Function Code	Parameter Name	Setting Range	Default	Property
FA-02	PID setting change time	Response time:0.00s to 650.00s	0.00s	☆
FA-03	PID feedback source	0: AI1 1: AI2 2: AI1 - AI2 3: Communication setting 4: Pulse setting (DI5) 5: AI1 + AI2 6: MAX( AI1 , AI2 ) 7: MIN( AI1 , AI2 )	0	☆
FA-04	PID action direction	0: Forward action 1: Reverse action	0	☆
FA-05	PID feedback range setting	0 to 65535	1000	☆
FA-06	Proportional gain Kp	0.0 to 100.0	20.0	☆
FA-07	Integral time Ti1	0.01s to 10.00s	2.00s	☆
FA-08	Differential time Td1	0.000s to 10.000s	0.000s	☆
FA-09	Cut-off frequency of PID reverse rotation	0.00Hz to maximum frequency(F0-14)	0.00Hz	☆
FA-10	Deviation limit	0.0% to 100.0%	0.0%	☆
FA-11	Differential limit	0.00% to 100.00%	0.10%	☆
FA-12	PID feedback filter time	0.00s to 60.00s	0.00s	☆
FA-13	Detection value of PID feedback loss	0.0% to 100.0%	0.0%	☆
FA-14	Detection time of PID feedback loss	0.0s to 3600.0s	3600.0s	☆
FA-18	Proportional gain Kip	0.0 to 100.0	20.0	☆
FA-19	Integral time Ti1	0.01s to 10.00s	2.00s	☆
FA-20	Differential time Td1	0.000s to 10.000s	0.000s	☆

Function Code	Parameter Name	Setting Range	Default	Property
FA-21	PID parameter switchover condition	0: No switchover 1: Switchover via DI 2: Automatic switchover based on deviation	0	☆
FA-22	PID parameter switchover deviation 1	0.0% to FA-23	20.0%	☆
FA-23	PID parameter switchover deviation 2	FA-22 to 100.0%	80.0%	☆
FA-24	PID initial value	0.0% to 100.0%	0.0%	☆
FA-25	PID initial value holding time	0.00s to 650.00s	0.00s	☆
FA-26	Maximum deviation between two PID outputs in forward direction	0.00% to 100.00%	1.00%	☆
FA-27	Maximum deviation between two PID outputs in reverse direction	0.00% to 100.00%	1.00%	☆
FA-28	PID integral property	Unit's digit: Integral separated 0: Effective 1: Ineffective Ten's digit: integral selection when output reached limit 0:Continue 1:Stop	00	☆
FA-29	PID operation at stop	0:No PID operation at stop 1: PID operation at stop	0	☆
Group Fb: Swing Frequency, Fixed Length and Count				
Fb-00	Swing frequency setting mode	0: Relative to the central frequency 1: Relative to the maximum frequency	0	☆
Fb-01	Swing frequency	0.0% to 100.0%	0.0%	☆

Function Code	Parameter Name	Setting Range	Default	Property
	amplitude			
Fb-02	Jump frequency amplitude	0.0% to 50.0%	0.0%	☆
Fb-03	Swing frequency cycle	0.1s to 3000.0s	10.0s	☆
Fb-04	Triangular wave rising time coefficient	0.1% to 100.0%	50.0%	☆
Fb-05	Set length	0m to 65535m	1000m	☆
Fb-06	Actual length	0m to 65535m	0m	☆
Fb-07	Number of pulses per meter	0.1 to 6553.5	100.0	☆
Fb-08	Set count value	1 to 65535	1000	☆
Fb-09	Designated count value	1 to 65535	1000	☆
<b>Group FC: Multi-Reference and Simple PLC Function</b>				
FC-00	Reference 0	-100.0% to 100.0%	0.0%	☆
FC-01	Reference 1	-100.0% to 100.0%	0.0%	☆
FC-02	Reference 2	-100.0% to 100.0%	0.0%	☆
FC-03	Reference 3	-100.0% to 100.0%	0.0%	☆
FC-04	Reference 4	-100.0% to 100.0%	0.0%	☆
FC-05	Reference 5	-100.0% to 100.0%	0.0%	☆
FC-06	Reference 6	-100.0% to 100.0%	0.0%	☆
FC-07	Reference 7	-100.0% to 100.0%	0.0%	☆
FC-08	Reference 8	-100.0% to 100.0%	0.0%	☆
FC-09	Reference 9	-100.0% to 100.0%	0.0%	☆
FC-10	Reference 10	-100.0% to 100.0%	0.0%	☆
FC-11	Reference 11	-100.0% to 100.0%	0.0%	☆

Function Code	Parameter Name	Setting Range	Default	Property
FC-12	Reference 12	-100.0% to 100.0%	0.0%	☆
FC-13	Reference 13	-100.0% to 100.0%	0.0%	☆
FC-14	Reference 14	-100.0% to 100.0%	0.0%	☆
FC-15	Reference 15	-100.0% to 100.0%	0.0%	☆
FC-16	Simple PLC running mode	0: Stop after the AC drive runs one cycle	0	☆
FC-16	Simple PLC running mode	1: Keep final values after the AC drive runs one cycle 2: Repeat after the AC drive runs one cycle	0	☆
FC-17	Simple PLC retentive selection	0: Non-retentive neither at power off nor after stop. 1: Retentive at power off but non-retentive after stop. 2: Non-retentive at power off but retentive after stop. 3: Retentive at power off and after stop.	0	☆
FC-18	Running time of simple PLC reference 0	0.0~6500.0	0.0	☆
FC-19	Acceleration/deceleration time of simple PLC reference 0	0 to 3 (Means acceleration/deceleration time 1 to 4 respectively )	0	☆
FC-20	Running time of simple PLC reference 1	0.0~6500.0	0.0	☆
FC-21	Acceleration/deceleration time of simple PLC reference 1	0 to 3 (Means acceleration/deceleration time 1 to 4 respectively )	0	☆
FC-22	Running time of simple PLC reference 2	0.0~6500.0	0.0	☆

Function Code	Parameter Name	Setting Range	Default	Property
FC-23	Acceleration/deceleration time of simple PLC reference 2	0 to 3 (Means acceleration/deceleration time 1 to 4 respectively )	0	☆
FC-24	Running time of simple PLC reference 3	0.0~6500.0	0.0	☆
FC-25	Acceleration/deceleration time of simple PLC reference 3	0 to 3 (Means acceleration/deceleration time 1 to 4 respectively )	0	☆
FC-26	Running time of simple PLC reference 4	0.0~6500.0	0.0	☆
FC-27	Acceleration/deceleration time of simple PLC reference 4	0 to 3 (Means acceleration/deceleration time 1 to 4 respectively )	0	☆
FC-28	Running time of simple PLC reference 5	0.0~6500.0	0.0	☆
FC-29	Acceleration/deceleration time of simple PLC reference 5	0 to 3 (Means acceleration/deceleration time 1 to 4 respectively )	0	☆
FC-30	Running time of simple PLC reference 6	0.0~6500.0	0.0	☆
FC-31	Acceleration/deceleration time of simple PLC reference 6	0 to 3 (Means acceleration/deceleration time 1 to 4 respectively )	0	☆
FC-32	Running time of simple PLC reference 7	0.0~6500.0	0.0	☆
FC-33	Acceleration/deceleration time of simple PLC reference 7	0 to 3 (Means acceleration/deceleration time 1 to 4 respectively )	0	☆
FC-34	Running time of simple PLC reference 8	0.0~6500.0	0.0	☆
FC-35	Acceleration/deceleration time of simple PLC	0 to 3	0	☆

Function Code	Parameter Name	Setting Range	Default	Property
	reference 8	(Means acceleration/deceleration time 1 to 4 respectively )		
FC-36	Running time of simple PLC reference 9	0.0~6500.0	0.0	☆
FC-37	Acceleration/deceleration time of simple PLC reference 9	0 to 3 (Means acceleration/deceleration time 1 to 4 respectively )	0	☆
FC-38	Running time of simple PLC reference 10	0.0~6500.0	0.0	☆
FC-39	Acceleration/deceleration time of simple PLC reference 10	0 to 3 (Means acceleration/deceleration time 1 to 4 respectively )	0	☆
FC-40	Running time of simple PLC reference 11	0.0~6500.0	0.0	☆
FC-41	Acceleration/deceleration time of simple PLC reference 11	0 to 3 (Means acceleration/deceleration time 1 to 4 respectively )	0	☆
FC-42	Running time of simple PLC reference 12	0.0~6500.0	0.0	☆
FC-43	Acceleration/deceleration time of simple PLC reference 12	0 to 3 (Means acceleration/deceleration time 1 to 4 respectively )	0	☆
FC-44	Running time of simple PLC reference 13	0.0~6500.0	0.0	☆
FC-45	Acceleration/deceleration time of simple PLC reference 13	0 to 3 (Means acceleration/deceleration time 1 to 4 respectively )	0	☆
FC-46	Running time of simple PLC reference 14	0.0~6500.0	0.0	☆
FC-47	Acceleration/deceleration time of simple PLC reference 14	0 to 3 (Means acceleration/deceleration time 1 to 4 respectively )	0	☆

Function Code	Parameter Name	Setting Range	Default	Property
FC-48	Running time of simple PLC reference 15	0.0~6500.0	0.0	☆
FC-49	Acceleration/deceleration time of simple PLC reference 15	0 to 3 (Means acceleration/deceleration time 1 to 4 respectively )	0	☆
FC-50	Time unit of simple PLC	0:s 1:h	0	☆
FC-51	Multi-Reference priority selection	0: No 1:Yes	1	☆
FC-52	Acceleration/deceleration time of multi-Reference	0: Acceleration/deceleration time 1 1: Acceleration/deceleration time 2 2: Acceleration/deceleration time 3 3: Acceleration/deceleration time 4	0	☆
FC-55	Reference 0 source	0: Keypad 1: AI1 2: AI2 3: Pulse setting 4: PID 5: Set by preset frequency (F0-11, modified via terminal UP/ DOWN)	0	☆
<b>Group Fd : Torque Control</b>				
Fd-00	Torque setting source in torque control	0: Keypad 1: AI1 2: AI2 3: Pulse setting 4: Communication setting 5: MAX( AI1 , AI2 )	0	★
Fd-00	Torque setting source in torque control	6: MIN( AI1 , AI2 ) (Full range of 1 to 6 corresponds to Fd-01)	0	★



Function Code	Parameter Name	Setting Range	Default	Property
Fd-01	Torque digital setting	-200.0% to 200.0%	150.0%	☆
Fd-03	Forward maximum frequency in torque	0.00Hz to maximum frequency(F0-14)	50.00Hz	☆
Fd-04	Reverse maximum frequency in torque	0.00Hz to maximum frequency(F0-14)	50.00Hz	☆
Fd-06	Torque setting filter time	0.00s to 10.00s	0.00s	☆
Fd-07	Acceleration time in torque control	0.0s to 1000.0s	10.0s	☆
Fd-08	Deceleration time in torque control	0.0s to 1000.0s	10.0s	☆
Fd-10	Speed/Torque control	0: Speed control 1: Torque control	0	★
Group FE: AI Curve Setting				
FE-00	AI curve 1 minimum input	-10.00V to FE-02	0.00	☆
FE-01	Corresponding setting of AI curve 1 minimum input	-100.0% to 100.0%	0.0%	☆
FE-02	AI curve 1 inflexion 1 input	FE-00 to FE-04	3.00	☆
FE-03	Corresponding setting of AI curve 1 inflexion 1 input	-100.0% to 100.0%	30.0%	☆
FE-04	AI curve 1 inflexion 2 input	FE-02to FE-06	6.00	☆
FE-05	Corresponding setting of AI curve 1 inflexion 2 input	-100.0% to 100.0%	60.0%	☆
FE-06	AI curve 1 maximum input	FE-06 to 10.00V	10.00	☆
FE-07	Corresponding setting of AI curve 1 maximum input	-100.0% to 100.0%	100.0%	☆
FE-08	AI curve 2 minimum input	-10.00V to FE-02	0.00V	☆
FE-09	Corresponding setting of AI curve 2 minimum input	-100.0% to 100.0%	0.0%	☆

Function Code	Parameter Name	Setting Range	Default	Property
FE-10	AI curve 2 inflexion 1 input	FE-00 to FE-04	3.00	☆
FE-11	Corresponding setting of AI curve 2 inflexion 1 input	-100.0% to 100.0%	30.0%	☆
FE-12	AI curve 2 inflexion 2 input	FE-02to FE-06	6.00	☆
FE-13	Corresponding setting of AI curve 2 inflexion 2 input	-100.0% to 100.0%	60.0%	☆
FE-14	AI curve 2 maximum input	FE-06 to 10.00V	10.00V	☆
FE-15	Corresponding setting of AI curve 2 maximum input	-100.0% to 100.0%	100.0%	☆
FE-24	Jump point of AI1 input corresponding setting	-100.0% to 100.0%	0.0%	☆
FE-25	Jump amplitude of AI1 input corresponding setting	0.0% to 100.0%	0.5%	☆
FE-26	Jump point of AI2 input corresponding setting	-100.0% to 100.0%	0.0%	☆
FE-27	Jump amplitude of AI2 input corresponding setting	0.0% to 100.0%	0.5%	☆
Group FF: Factory Parameters				
FF-00	User code	0 to 65535	*****	☆
Group H0: Motor 2 Parameters Setting				
H0-00	Motor selection	1: Motor 1 2: Motor 2	1	★
H0-01	Motor 2 control mode	1: Open loop flux vector control (Speed-sensorless vector control) 2: Voltage/Frequency (V/F) control	2	★
H0-02	Motor 2 acceleration/deceleration time	0: Same as motor 1 1: Acceleration/deceleration time 1 2: Acceleration/deceleration time 2	0	☆

Function Code	Parameter Name	Setting Range	Default	Property
		3: Acceleration/deceleration time 3 4: Acceleration/deceleration time 4		
<b>Group H1: Motor 2 Parameters</b>				
H1-00	Auto-tuning selection	0: No auto-tuning 1: Static auto-tuning 2: Complete auto-tuning	0	★
H1-01	Rated motor 2 power	0.4kW to 1000.0kW	Model dependent	★
H1-02	Rated motor 3 voltage	0V to 1500V	380V	★
H1-03	Number of pole pairs of motor 2	2 to 64	Model dependent	●
H1-04	Rated motor 2 current	0.01A to 600.00 A (motor rated power $\leq 30$ kW) 0.1A to 6000.0 A (motor rated power $> 30$ kW)	H1-01 dependent	★
H1-05	Rated motor 2 frequency	0.00Hz to F0-14	50.00Hz	★
H1-06	Rated motor 2 rotational speed	0rpm to 30000rpm	H1-01 dependent	★
H1-07	Motor 2 no-load current	0.01A to H1-04 A (motor rated power $\leq 30$ kW) 0.1A to H1-04 A (motor rated power $> 30$ kW)	H1-01 dependent	★
H1-08	Motor 2 stator resistance	0.001 $\Omega$ to 65.535 $\Omega$	Model dependent	★
H1-09	Motor 2 rotor resistance	0.001 $\Omega$ to 65.535 $\Omega$	Model dependent	★
H1-10	Motor 2 mutual inductive	0.1mH to 6553.5mH	Model dependent	★
H1-11	Motor 2 leakage inductive	0.01mH to 655.35mH	Model dependent	★

Function Code	Parameter Name	Setting Range	Default	Property
H1-12	Acceleration time of complete auto-tuning	1.0s to 600.0s	10.0s	☆
H1-13	Deceleration time of complete auto-tuning	1.0s to 600.0s	10.0s	☆
Group H2: Motor 2 V/F Control Parameters				
H2-00	Torque boost	0.0% ~ 30.0%	0.0%	☆
H2-02	Oscillation suppression gain	0 to 100	Model dependent	☆
Group H3: Motor 2 Vector Control Parameters				
H3-00	Switchover frequency 1	1.00Hz to H3-02	5.00Hz	☆
H3-02	Switchover frequency 2	H3-00 to F0-14	10.00Hz	☆
H3-04	Speed loop proportional gain at low frequency	1.0 to 10.0	4.0	☆
H3-05	Speed loop integral time at low frequency	0.01s to 10.00s	0.50s	☆
H3-06	Speed loop proportional gain at high frequency	1.0 to 10.0	2.0	☆
H3-07	Speed loop integral time at high frequency	0.01s to 10.00s	1.00s	☆
H3-08	Speed loop integral property	0: integral effect 1: integral separation	0	★
H3-11	Torque adjustment proportional gain Kp	0 to 30000	2000	☆
H3-12	Torque adjustment integral gain Ki	0 to 30000	1300	☆
H3-13	Excitation adjustment proportional gain Kp	0 to 30000	2000	☆

Function Code	Parameter Name	Setting Range	Default	Property
H3-14	Excitation adjustment integral gain Ki	0 to 30000	1300	☆
H3-15	Flux braking gain	100 to 200	110	☆
H3-16	Field weakening torque correction ratio	50% to 200%	100%	☆
H3-17	Slip compensation gain	50% to 200%	100%	☆
H3-18	Speed loop feedback filter time	0.000s to 1.000s	0.015s	☆
H3-19	Speed loop output filter time	0.000s to 1.000s	0.000s	☆
H3-20	Source of power-driven torque upper limit	0: F3-21 1: AI1 2: AI2 3: Communication setting 4: Pulse setting (DI5) (Analog range corresponds to H3-21)	0	☆
H3-21	Power-driven torque upper limit	0.0% to 200.0%	150.0%	☆
H3-22	Source of braking torque upper limit	0: F3-23 1: AI1 2: AI2 3: Communication setting 4: Pulse setting (DI5) (Analog range corresponds to H3-23)	0	☆
H3-23	Braking torque upper limit	0.0% to 200.0%	150.0%	☆

Function Code	Parameter Name	Setting Range	Default	Property
Group L0: System Parameters				
L0-00	Parameters only for reading	0: Disable 1: Enable	1	☆
Group L1: User - defined Parameters				
L1-00	Clear user-defined parameters	0: Disable 1: Enable	0	☆
L1-01	User-defined parameters 1	uF0-00 to uU1-xx	uF0-03	☆
L1-02	User-defined parameters 2	uF0-00 to uU1-xx	uF0-04	☆
L1-03	User-defined parameters 3	uF0-00 to uU1-xx	uF0-06	☆
L1-04	User-defined parameters 4	uF0-00 to uU1-xx	uF0-23	☆
L1-05	User-defined parameters 5	uF0-00 to uU1-xx	uF0-24	☆
L1-06	User-defined parameters 6	uF0-00 to uU1-xx	uF4-00	☆
L1-07	User-defined parameters 7	uF0-00 to uU1-xx	uF4-01	☆
L1-08	User-defined parameters 8	uF0-00 to uU1-xx	uF4-02	☆
L1-09	User-defined parameters 9	uF0-00 to uU1-xx	uF4-04	☆
L1-10	User-defined parameters 10	uF0-00 to uU1-xx	uF4-05	☆
L1-11	User-defined parameters 11	uF0-00 to uU1-xx	uF4-06	☆
L1-12	User-defined parameters 12	uF0-00 to uU1-xx	uF4-12	☆
L1-13	User-defined parameters 13	uF0-00 to uU1-xx	uF4-13	☆
L1-14	User-defined parameters 14	uF0-00 to uU1-xx	uF5-00	☆
L1-15	User-defined parameters 15	uF0-00 to uU1-xx	uF5-01	☆
L1-16	User-defined parameters 16	uF0-00 to uU1-xx	uF5-02	☆
L1-17	User-defined parameters 17	uF0-00 to uU1-xx	uF6-00	☆
L1-18	User-defined parameters 18	uF0-00 to uU1-xx	uF6-01	☆

Function Code	Parameter Name	Setting Range	Default	Property
L1-19	User-defined parameters 19	uF0-00 to uU1-xx	uF0-00	☆
L1-20	User-defined parameters 20	uF0-00 to uU1-xx	uF0-00	☆
L1-21	User-defined parameters 21	uF0-00 to uU1-xx	uF0-00	☆
L1-22	User-defined parameters 22	uF0-00 to uU1-xx	uF0-00	☆
L1-23	User-defined parameters 23	uF0-00 to uU1-xx	uF0-00	☆
L1-24	User-defined parameters 24	uF0-00 to uU1-xx	uF0-00	☆
L1-25	User-defined parameters 25	uF0-00 to uU1-xx	uF0-00	☆
L1-26	User-defined parameters 26	uF0-00 to uU1-xx	uF0-00	☆
L1-27	User-defined parameters 27	uF0-00 to uU1-xx	uF0-00	☆
L1-28	User-defined parameters 28	uF0-00 to uU1-xx	uF0-00	☆
L1-29	User-defined parameters 29	uF0-00 to uU1-xx	uF0-00	☆
L1-30	User-defined parameters 30	uF0-00 to uU1-xx	uF0-00	☆
L1-31	User-defined parameters 31	uF0-00 to uU1-xx	uF0-00	☆
Group L2: Optimization Parameters				
L2-00	Dead zone compensation selection	0: No compensation 1: Compensation	1	☆
L2-01	PWM modulation mode	0: Asynchronous modulation 1: Synchronous modulation	0	☆
L2-02	PWM seven phase/five phase selection	0: Seven phase in whole course 1: Seven phase/five phase auto switchover	0	☆
L2-03	CBC current limit	0: Disable    1: Enable	1	☆
L2-04	Braking threshold	350.0V to 780.0V	360.0V	☆
			690.0V	
L2-05	Under voltage threshold	200.0V to 500.0V	200.0V	☆

Function Code	Parameter Name	Setting Range	Default	Property
			350.0V	
L2-06	Random PWM depth	0 to 6	0	☆
L2-07	0Hz running way	0: No current output 1: Normal operation 2: Output with DC braking current F1-16	0	☆
L2-08	Limitation of low frequency carrier	0: Limitation mode 0 1: Limitation mode 1 2: Unlimited (the carrier waves are in accordance in every frequency ranges)	0	☆
Group L3: AI/AO Correction				
L3-00	AI1 displayed voltage 1	-9.999V to 10.000V	3.000V	☆
L3-01	AI1 measured voltage 1	-9.999V to 10.000V	3.000V	☆
L3-02	AI1 displayed voltage 2	-9.999V to 10.000V	8.000V	☆
L3-03	AI1 measured voltage 2	-9.999V to 10.000V	8.000V	☆
L3-04	AI2 displayed voltage 1	-9.999V to 10.000V	3.000V	☆
L3-05	AI2 measured voltage 1	-9.999V to 10.000V	3.000V	☆
L3-06	AI2 displayed voltage 2	-9.999V to 10.000V	8.000V	☆
L3-07	AI2 measured voltage 2	-9.999V to 10.000V	8.000V	☆
L3-12	AO1 target voltage 1	-9.999V to 10.000V	3.000V	☆
L3-13	AO1 measured voltage 1	-9.999V to 10.000V	3.000V	☆
L3-14	AO1 target voltage 2	-9.999V to 10.000V	8.000V	☆
L3-15	AO1 target voltage 2	-9.999V to 10.000V	8.000V	☆
L3-16	AO2 measured voltage 1	-9.999V to 10.000V	3.000V	☆
L3-17	AO2 target voltage 1	-9.999V to 10.000V	3.000V	☆



Function Code	Parameter Name	Setting Range	Default	Property
L3-18	AO2 measured voltage 2	-9.999V to 10.000V	8.000V	☆
L3-19	AO2 target voltage 2	-9.999V to 10.000V	8.000V	☆
<b>Group L4: Master-slave Control Parameters</b>				
L4-00	Master-slave control selection	0: Disable 1: Enable	0	★
L4-01	Master-slave selection	0: Master 1: Slave	0	★
L4-02	Master sending frequency selection	0: Running frequency 1: Target frequency	0	★
L4-03	Command source selection of slave followed the master	0: Non-follow 1: Follow	0	★
L4-04	Slave received frequency coefficient	-10.00 to 10.00	1.00	☆
L4-05	Slave received torque coefficient	-10.00 to 10.00	1.00	☆
L4-06	Slave received torque offset	-50.00% to 50.00%	0.00%	☆
L4-07	Frequency offset threshold	0.20% to 10.00%	0.50%	☆
L4-08	Master-slave communication offline detection time	0.00s to 10.00s	0.10S	☆
<b>Group L5: Braking Function Parameters</b>				
L5-00	Braking control selection	0: Disable 1: Enable	0	★
L5-01	Braking loosen frequency	0.00Hz to 20.00Hz	2.50Hz	★
L5-02	Braking loosen frequency	0.0s to 20.0s	1.0s	★

Function Code	Parameter Name	Setting Range	Default	Property
	holding time			
L5-03	Braking period current threshold	50.0% to 200.0%	120.0%	★
L5-04	Braking actuation frequency	0.00Hz to 20.00Hz	1.50Hz	★
L5-05	Braking actuation delay time	0.0s to 20.0s	0.0s	★
L5-06	Braking actuation frequency holding time	0.0s to 20.0s	1.0s	★
<b>Group L6: Sleep Wake-up Function Parameters</b>				
L6-00	Sleep selection	0:Sleep function ineffective 1:DI terminal control 2:PID setting and feedback control 3: Running frequency control	0	☆
L6-01	Sleep frequency	0.00Hz to 50.00Hz	0.00Hz	☆
L6-02	Sleep delay time	0.0s to 3600.0s	60.0s	☆
L6-03	Wake-up deviation	0.0% to 100.0%	10.0%	☆
L6-04	Wake-up delay time	0.0s to 3600.0s	0.5s	☆

Function Code	Parameter Name	Min. Unit	Property
<b>Group U0: Error Recording Parameters</b>			
U0-00	3 <sup>rd</sup> (latest) fault type	00:No fault Err01: Inverter unit protection	1 ●

Function Code	Parameter Name		Min. Unit	Property
U0-01	2 <sup>nd</sup> fault type	Err04: Overcurrent during acceleration Err05: Overcurrent during deceleration Err06: Over current at constant speed Err08: Overvoltage during acceleration Err09: Overvoltage during deceleration Err10: Overvoltage at constant speed Err12: Under voltage Err13: Drive overload Err14: Motor overload Err15: Drive overheat Err17: Current detection fault Err20: Short circuit to ground Err23: Power input phase loss Err24: Power output phase loss Err25: EEPROM read-write fault Err27: Communication fault Err28: External equipment fault Err29: Too large speed deviation Err30: User-definedfault1 Err31: User-definedfault2	1	●
U0-02	1 <sup>nd</sup> fault type	Err32: PID feedback lost during running Err33: Fast current limit fault	1	●

Function Code	Parameter Name	Min. Unit	Property
	Err34: Load becoming 0 Err35: Control power supply fault Err37: Control power supply fault Err39: Current running time reached Err40: Accumulative running time reached Err42: Motor switchover fault during running Err46: Master slave control communication disconnection		
U0-03	Frequency upon the 3 <sup>rd</sup> fault	0.01Hz	●
U0-04	Current upon the 3 <sup>rd</sup> fault	0.01A	●
U0-05	Bus voltage upon the 3 <sup>rd</sup> fault	0.1V	●
U0-06	DI status upon the 3 <sup>rd</sup> fault	1	●
U0-07	Output terminal status upon the 3 <sup>rd</sup> fault	1	●
U0-08	AC drive status upon the 3 <sup>rd</sup> fault	1	●
U0-09	Power-on time upon the 3 <sup>rd</sup> fault	1min	●
U0-10	Running time upon the 3 <sup>rd</sup> fault	1min	●
U0-13	Frequency upon the 2 <sup>nd</sup> fault	0.01Hz	●
U0-14	Current upon the 2 <sup>nd</sup> fault	0.01A	●
U0-15	Bus voltage upon the 2 <sup>nd</sup> fault	0.1V	●
U0-16	DI status upon the 2 <sup>nd</sup> fault	1	●
U0-17	Output terminal status upon the 2 <sup>nd</sup> fault	1	●
U0-18	AC drive status upon the 2 <sup>nd</sup> fault	1	●

Function Code	Parameter Name	Min. Unit	Property
U0-19	Power-on time upon the 2 <sup>nd</sup> fault	1min	●
U0-20	Running time upon the 2 <sup>nd</sup> fault	1min	●
U0-21	Reserved		●
U0-22	Reserved		●
U0-23	Frequency upon the 1 <sup>st</sup> fault	0.01Hz	●
U0-24	Current upon the 1 <sup>st</sup> fault	0.01A	●
U0-25	Bus voltage upon the 1 <sup>st</sup> fault	0.1V	●
U0-26	DI status upon the 1 <sup>st</sup> fault	1	●
U0-27	Output terminal status upon the 1 <sup>st</sup> fault	1	●
U0-28	AC drive status upon the 1 <sup>st</sup> fault	1	●
U0-29	Power-on time upon the 1 <sup>st</sup> fault	1min	●
U0-30	Running time upon the 1 <sup>st</sup> fault	1min	●
Group U1: Application Monitoring Parameters			
U1-00	Running frequency	0.01Hz	●
U1-01	Setting frequency	0.01Hz	●
U1-02	Bus voltage	0.1V	●
U1-03	Output voltage	1v	●
U1-04	Output current	0.1A	●
U1-05	Output power	0.1kW	●
U1-06	DI input status, hexadecimal	1	●
U1-07	DO output status, hexadecimal	1	●
U1-08	AI1 voltage after correction	0.01V	●
U1-09	AI2 voltage after correction	0.01V	●

Function Code	Parameter Name	Min. Unit	Property
U1-10	PID setting, PID setting ( percentage)×FA-05	1	●
U1-11	PID feedback, PID feedback ( percentage)×FA-05	1	●
U1-12	Count value	1	●
U1-13	Length value	1	●
U1-14	Motor speed	1rpm	●
U1-15	PLC stage	1	●
U1-16	Input pulse frequency	0.01kHz	●
U1-17	Feedback speed	0.1Hz	●
U1-18	Remaining running time of F7-38 setting	0.1min	●
U1-19	AI1 voltage before correction	0.001v	●
U1-20	AI2 voltage before correction	0.001v	●
U1-21	HDI5 high speed pulse sampling linear speed	1m/min	●
U1-22	Load speed display	1rpm	●
U1-23	Current power-on time	1min	●
U1-24	Current running time	0.1min	●
U1-25	Pulse input frequency	1Hz	●
U1-26	Communication setting value	0.01%	●
U1-27	Main frequency X	0.01Hz	●
U1-28	Auxiliary frequency Y	0.01Hz	●
U1-29	Target torque	0.1%	●
U1-30	Output torque	0.1%	●
U1-31	Output torque	0.1%	●
U1-32	Torque upper limit	0.1%	●

Function Code	Parameter Name	Min. Unit	Property
U1-33	Target voltage upon V/F separation	1V	●
U1-34	Output voltage upon V/F separation	1V	●
U1-35	Reserved		●
U1-36	Current motor number		●
U1-37	AO1 target voltage	0.01V	●
U1-38	AO2 target voltage	0.01V	●
U1-39	AC drive running status: 0: Stop 1: Forward 2: Reverse 3: Fault	1	●
U1-40	AC drive current fault	1	●



**Advanced Control®**, Advanced Systems Baltic OÜ  
Punane 73, 13619 Tallinn, Estonia  
Phone: +372 622 82 20, Fax: +372 622 82 21  
Web: [www.advancedcontrol.eu](http://www.advancedcontrol.eu), e-mail: [info@advancedcontrol.eu](mailto:info@advancedcontrol.eu)